



CORiTEC one[®]

CORiTEC one[®]

THE INTELLIGENT PRACTICE LAB SOLUTION

The new CORiTEC one machine system is fitting perfectly for processing any common CAD/CAM blocks up to a size of 65 x 40 x 20 mm (maxi blocks). Thanks to the robust axis kinematics the machine is also able to process premilled abutments.

The high-quality construction out of cast aluminium guarantees best stability while maintaining the smallest footprint. The system is equipped with an integrated high-performance PC and a big touch screen display which facilitates a comfortable and ergonomic operation. The 3-fold block holder and 6 tools positions with sister (twin) tool function enable an efficient, safe and fast operating process with highest quality. In combination with all open scanners the CORiTEC one is ideally convenient for practice labs. As a supplemental system for the specialized processing of glass ceramics, zirconia, composite and premilled abutments the CORiTEC one leaves nothing to be desired either for clinics, labs or milling centers.



approx. 15.7 inch / 40 cm













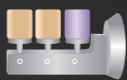



- WET
- DRY
- 4 AX
- 3 mm
6x
- Temperature control icon
- Touch screen icon
- Block holder icon
- Tool holder icon
- ION

CORiTEC one®

HIGHLIGHTS

- novel closed mono-block cast body for stability and precision
- self-sufficient operation without external compressed air possible
- optimized for the integrated CAD/CAM workflow with exocad/3shape
- very fast grinding and milling process
- short amortization period
- minimal footprint
- high precision due to integrated temperature compensation
- machining of all common material blocks and prefabricated abutments
- multi-adapter for up to three standard blocks or maxi blocks (65 x 40 x 20 mm)



| | | | | | | | | | |
|----------------|------------------|---------------------------------------------------------------------------------------|---------------------------------------------------------------------------------------|---------------------------------------------------------------------------------------|---------------------------------------------------------------------------------------|---------------------------------------------------------------------------------------|---------------------------------------------------------------------------------------|---------------------------------------------------------------------------------------|---------------------------------------------------------------------------------------|
| PMMA | WAX | L-holder | 3-fold holder | 1-fold PreFab Abutment holder | Crown, Bridge | Inlay, Onlay Veneer | Hybrid Abutment | Splint | |
| Zr | COMPOSITE |  |  |  |  |  |  |  | |
| PEEK | SINT |  |  |  |  |  |  |  |  |
| Glass ceramics | PreFab Abutments | | | | | | | | |
| CoCr | Ti | | | | | | | | |

MAX PERFORMANCE

**in grinding
and milling**



Applications and holders

GRINDING BLOCK MATERIALS

- production of all materials in wet grinding (e.g. glass-ceramics and lithium disilicate)
- adapter also suitable for blocks of nano-composite



MILLING OF ZIRCONIA BLOCKS

- pre- and dence-sintered multi colour zirconia blocks
- all ceramic framework materials which meets highest aesthetic demands
- maxiblock up to 65 x 20 x 40 mm size



PREFABRICATED ABUTMENTS

- integrated systems: DESS, nt-trading, Medentika, Dental Direkt
- 360 degree processing possible
- short set-up time due to multi-adapter



BIOHPP ELEGANCE PREFABS

- individual hybrid abutment on PEEK basis
- BioHPP for permanent dentures, free of metal, oxide and monomer
- homogeneous combination of titanium and BioHPP



T1/T6 - 3.0 | 3.0 mm
radius milling tool (l = 15 mm)

| | |
|----|------|
| T1 | Ti |
| T6 | CoCr |

3,0 mm Ø 3 mm

up to 15 mm

Blades

Art.-No. 526018 3003

T11/T13 - 2.5 | 3.0 mm
radius milling tool

| | |
|-----|-----------|
| T11 | PMMA |
| T13 | WAX Zr |

2,5 mm Ø 3 mm

up to 25 mm

Blades

Art.-No. 526016 2503

T2/T7 - 2.0 | 3.0 mm
radius milling tool (l = 12 mm)

| | |
|----|------|
| T2 | Ti |
| T7 | CoCr |

2,0 mm Ø 3 mm

up to 15 mm

Blades

Art.-No. 526018 2003

T12 - 1.0 | 3.0 mm
radius milling tool (single blade, slide coated)

| | |
|-----|---------------------|
| T12 | PMMA WAX PEEK |
|-----|---------------------|

1,0 mm Ø 3 mm

up to 25 mm

Blade

Art.-No. 526004 1003c

T3/T8/T16 - 1.5 | 3.0 mm
radius milling tool (l = 12 mm), universal

| | |
|-----|-----------|
| T3 | UNIVERSAL |
| T8 | |
| T16 | |

1,5 mm Ø 3 mm

up to 15 mm

Blades

Art.-No. 526000 1503

T12/T14 - 1.0 | 3.0 mm
radius milling tool

| | |
|-----|-------------|
| T12 | PMMA WAX |
| T14 | Zr |

1,0 mm Ø 3 mm

up to 25 mm

Blades

Art.-No. 526016 1003

T4/T9 - 1.0 | 3.0 mm
radius milling tool (l = 9 mm)

| | |
|----|------|
| T4 | Ti |
| T9 | CoCr |

1,0 mm Ø 3 mm

up to 25 mm

Blades

Art.-No. 526001 1503

T13/T40/T50 - 2.5 | 3.0 mm
radius milling tool (diamond coated)

| | |
|-----|------|
| T13 | Zr |
| T40 | SINT |
| T50 | COMP |

2,5 mm Ø 3 mm

up to 25 mm

Blades

Art.-No. 526013 2503

T11 - 2.5 | 3.0 mm
radius milling tool (single blade, slide coated)

| | |
|-----|---------------------|
| T11 | PMMA WAX PEEK |
|-----|---------------------|

2,5 mm Ø 3 mm

up to 25 mm

Blade

Art.-No. 526004 2503c

T15/T42/T52 - 0.6 | 3.0 mm
radius milling tool (conical)

| | |
|-----|-------------------|
| T15 | PMMA WAX Zr |
| T42 | SINT |
| T52 | COMP |

0,6 mm Ø 3 mm

up to 25 mm

Blades

Art.-No. 526016 0603

T21 - 2.5 | 3.0 mm
radius grinding tool (diamond)

| | |
|-----|-------------------|
| T21 | glass ceramics |
|-----|-------------------|

2,5 mm Ø 3 mm

up to 25 mm

Diamond icon

Art.-No. 526005 2503

T23 - 0.6 | 3.0 mm
radius grinding tool (conical, diamond)

| | |
|-----|-------------------|
| T23 | glass ceramics |
|-----|-------------------|

0,6 mm Ø 3 mm

up to 25 mm

Diamond icon

Art.-No. 526005 0603

T22 - 1.0 | 3.0 mm
radius grinding tool (diamond)

| | |
|-----|-------------------|
| T22 | glass ceramics |
|-----|-------------------|

1,0 mm Ø 3 mm

up to 25 mm

Diamond icon

Art.-No. 526005 1003

CORiTEC smart control™

SMART CONTROL OF MACHINE SOFTWARE

smart control™ one touch ahead!

The newly developed control software „smart control™“ enables absolutely intuitive operation of our milling machines. From selecting the job to milling or querying the machine status; the self-explanatory and optimized handling makes it possible to start operating the machine in the shortest possible time. Starting a milling process requires only two clicks – benefit from the smart time savings for your workflow!

FEATURES

- modern touch control design
- straightforward operation with intuitive graphical interface
- high end performance for imes-icore® machines
- remote monitoring
- job management with 3D preview
- 3D simulation

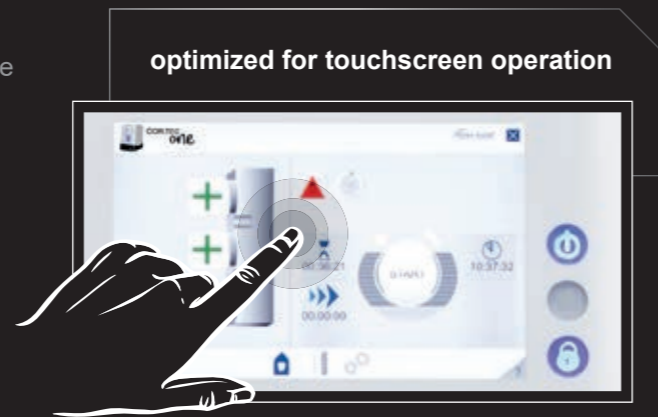

automated transfer of information from the CAM software



ideal tool management



Scanner COMPATIBLE WITH **exocad** AND **3shape**▶

CORiTEC i3Dscan eco

- all-round carefree package for newcomers or small laboratories
- simple, fast, low-priced
- very compact design



CORiTEC i3Dscan color

- the object to be scanned is automatically guided into the measuring field
- modern touch control design
- the 180-degree opening offers a large working area



CORiTEC i3Dscan color HR

- enormously high scanning efficiency and precision (4 µm)
- Color Texture scan
- Blue-Light LED & High resolution camera (2.8 MP)
- all modules included in the scope of delivery

CAM software

CORiTEC iCAM V4.7

- all strategies optimized for 5-axis simultaneous machining
- 64-bit multi-core support
- no annual license fees
- validated post-processors for all imes-icore® CORiTEC machines



CORiTEC iCAM V5

- all strategies optimized for 5-axis simultaneous machining
- automatic exchange of implant connections (ReFit option)
- no annual license fees
- fully automatic and easy operation with “Wizard Workflow“



Full integrated workflow

OPEN TO ALL COMMON SCANNERS



Suction system

iVAC silent

The system is equipped with a teflon filter cartridge, automatic filter cleaning and a dust drawer. With the suction power of 160 m³/h the iVAC silent is perfectly suited for your CORITEC one and is even stowable in the optional machine table.

| iVAC silent | |
|------------------------|---------------------------------------------------------|
| airflow | 160 m ³ /hr |
| power | 490 W |
| filter system | Teflon filter cartridge - automatic cleaning feature |
| filter volume | 2.6 liters (dust drawer) |
| width x depth x height | 9.7 x 19.7 x 17.3 inch / 245 x 500 x 440 mm |
| supply voltage | 230 V |
| special features | quiet running, very compact, self-cleaning by vibration |

Machine table

MACHINE TABLE T0

The T0 offers stability and appealing optics. Steady castors guarantee the secure mobility of your machine. The dimensions of 400 x 540 x 900 mm/ 15.4 x 21.3 x 35.4 inch (W x D x H) provide sufficient utility space. Focusing on space-saving the T0 is equipped with drawers, cable bushing and storage room for the respective suction unit.



Dimensions

CORiTEC one®

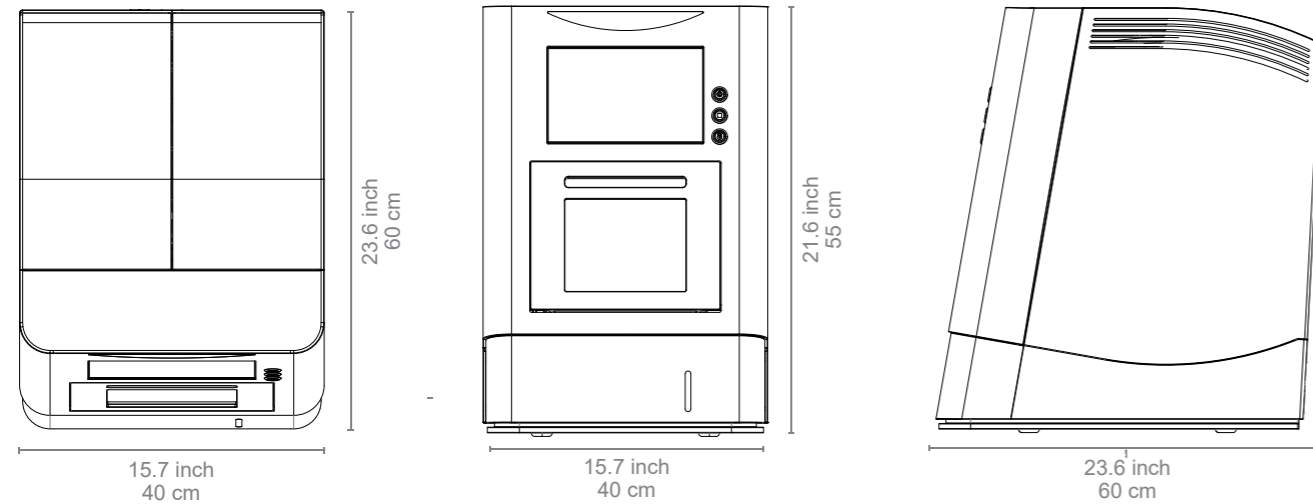

Machine table T0

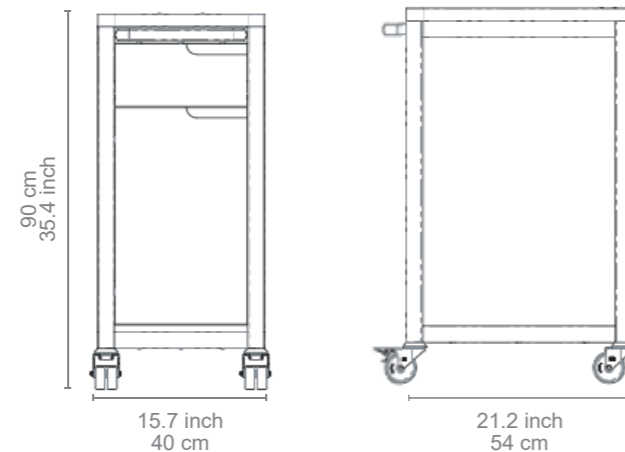

In numbers

mechanics / electronics

| | |
|-----------------------------------|--------------------------------------------------------|
| number of axes and operation type | 4 axes, simultaneous processing |
| angle of rotation | A-axis 360° |
| spindle | high-frequency spindle |
| maximum speed | 100.000 rpm |
| tools | milling and grinding tools with 3 mm tool shaft |
| tool changer | 6-fold |
| tool length control | ≤ 0.002 mm precision |
| integrated PC | Windows based |
| monitor | integrated 10" touch screen |
| illumination | 3 LED status colors |
| software | smart control™ integrated CNC software |
| air pressure | no external air pressure needed, compressor integrated |
| cooling liquid | integrated tank |

connecting requirements

| | |
|------------------------------------------|----------------------------------------------|
| weight | 65 kg |
| width x depth x height | 15.7 x 23.6 x 21.6 inch / 400 x 600 x 550 mm |
| line voltage / frequency / maximum power | 100 V - 230 V / 50/60 Hz / 500 W |

Sales and support partner worldwide



Represented for you in over 100 countries.

imes-icore® GmbH has been a leading manufacturer and technology partner since 2003 in the field of dental CAD/CAM systems and solutions.

With your unique range of dental milling and grinding systems imes-icore® offers a perfect selection for all individual requirements of dental laboratories, milling centres and dental practices of all sizes.

Our “Open-System” product philosophy makes it possible to easily integrate our milling machines into your existing workflow and to integrate them with your open scanners and your CAD/CAM software. We are open for your material selection.

imes-icore® GmbH

Fon +49 (0) 66 72/898 228

Fax +49 (0) 66 72/898 222

dental@imes-icore.de